

AMP CONDENSING BOILERS - SUBMITTAL DATA SHEET

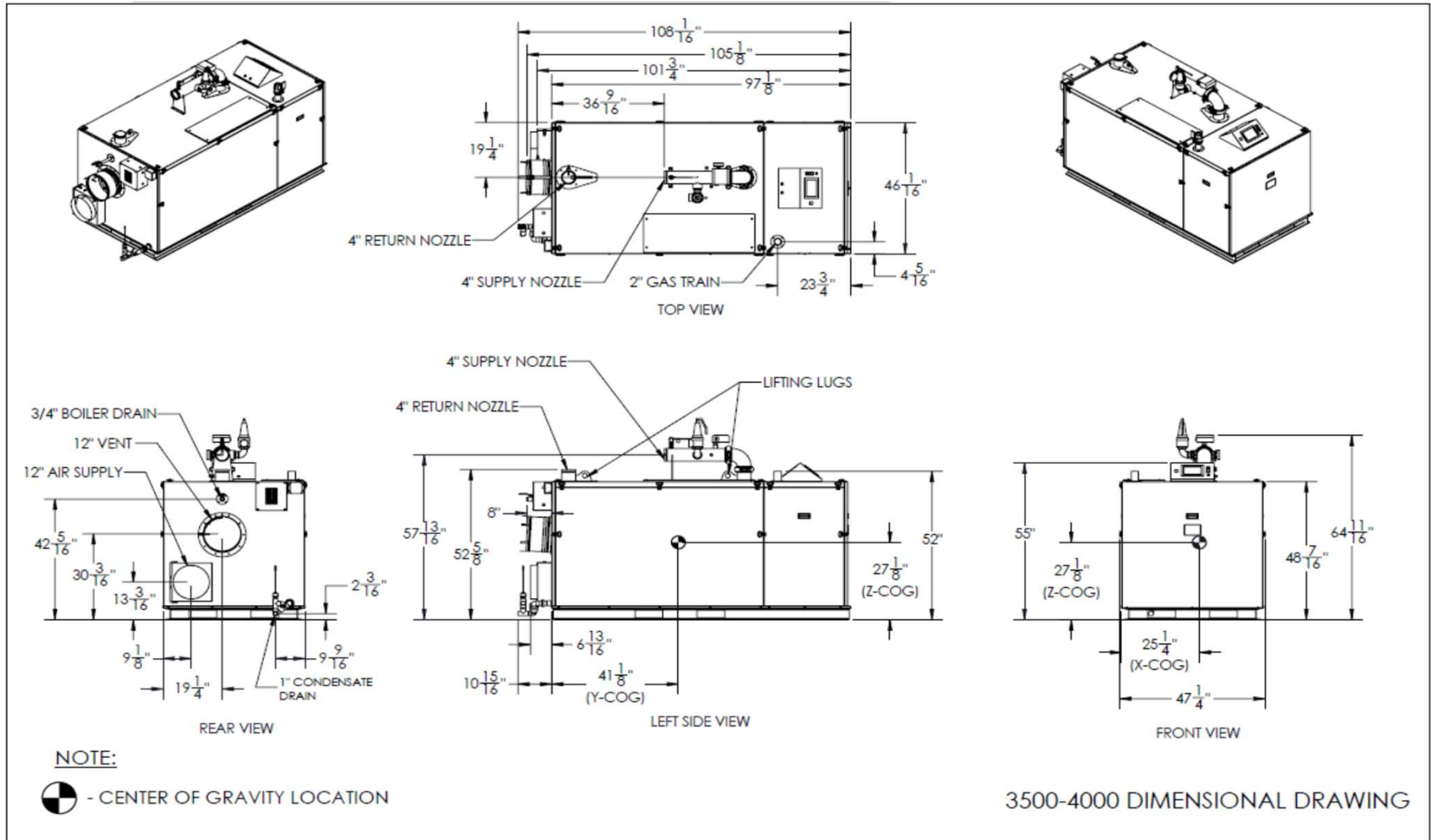

AMP CONDENSING BOILERS - SUBMITTAL DATA SHEET

RATINGS AND CAPACITIES		
Input - Low fire:	700,000	BTU/HR
Input - High Fire:	3,500,000	BTU/HR
Output - High Fire:	3,395,000	BTU/HR
Boiler Horsepower:	101.4	BHP
Thermal Efficiency:	97.0%	
Low Fire Thermal Efficiency:	Up to 99%	
Heating Surface:	403	Sq.Ft.
Water Content:	45.3	Gallons
Fuel:	Natural Gas or LP Gas	
Firing Rate:	Full Modulation	
Burner Turndown:	5:1	
Low NOx Emissions:	< 10 ppm	
Inlet Gas Pressure (NG):	4" wc	Min.
Inlet Gas Pressure (LP):	8" wc	Min.
	14" wc	Max.
Shipping Weight, Approximate:	2,485	lbs
ASME Section IV (Max 160 PSIG / 210°F) Setpoint range is 60-185°F Adjustable, manual reset high limit setting of ≤ 200°F. ASME H stamp MAWT is 210°F for the vessel. (For max setpoint, see Setpoint range.)		
ETL Certified to ANSI Z21.13 / CSA 4.9 ETL Certified to UL 795 / CSA 3.1		
DIMENSIONS / CONNECTIONS		
Height:	55"	(Note 1)
Width:	46"	(Note 2)
Length:	97 1.8"	(Note 3)
Supply Connection:	4" Grooved	
Return Connection:	4" Grooved	
Vent / Air Intake Connections:	12"	
Condensate / Boiler Drain Connection:	1"	
Gas Connection:	2" NPT	

FLOWS AND PRESSURE DROPS		
Delta T	Flow (GPM)	Δ P (Ft. Hd)
20°F Δ T (Max)	340	15.5
25°F Δ T	272	10.6
30°F Δ T	226	8.1
35°F Δ T	194	6.5
40°F Δ T	170	5.3
45°F Δ T	151	4.4
50°F Δ T	136	3.7
55°F Δ T (Min)	123	3.5

- NOTES:** 1. Height dimension is from floor to top of jacket.
 2. Length is from jacket front to jacket rear.
 3. Dimensions shown are for reference only

AMP CONDENSING BOILERS - SUBMITTAL DATA SHEET

STANDARD EQUIPMENT

PRESSURE VESSEL DESIGN

Stainless Steel Heat Exchanger
 ASME Section IV Certified, "H" Stamp
 MAWP 160 PSIG & Max Temp 210°F
 Setpoint range is 60-185°F
 Adjustable, manual reset high limit setting of ≤ 200°F.
 ASME H stamp MAWT is 210°F for the vessel. (For max setpoint, see Setpoint range.)
 Ten Year Limited Pressure Vessel Warranty

COMBUSTION DESIGN

Stainless Steel Pre-Mix Burner
 Low NOx Emissions (< 10 ppm)
 Full Modulation, 5:1 Turndown
 Natural Gas, Propane or Dual Fuel (Gas/Gas)
 4" wc (8" wc Propane) to 14" wc inlet gas pressure
 Direct Spark Ignition System with UV Scanner
 High/Low gas pressure switches, manual reset
 Zero governor gas valve
 Variable Speed Combustion Blower
 Air Proving Switch
 Blocked Vent Switch
 Manual fuel changeover switch (Dual Fuel Only)

VENTING

Category II or IV Venting
 Individual or Common (Engineered) Vent System
 Vertical or Horizontal
 CPVC, PP or SS Venting *Materials Acceptable
 Combustion Air Intake - Sealed or Room

* Flue system material shall be capable of continuous operation at 210°F or higher and shall be certified to UL 1738 – venting system for gas-burning appliances cat II, III and IV.

BOILER EQUIPMENT

Concert™ Control (24 Vac)
 High Limit Temp Control, Manual Reset
 Low water cutoff, manual reset
 Water Flow Switch
 Supply & Return Water Temperature Sensors
 Flue Gas Temperature Sensor
 Condensate trap
 Blocked Condensate Switch
 Pressure & Temperature Gauge
 ASME Relief Valve
 (Available 30, 50, 60, 75, 100, 125 or 150 psig)

ELECTRICAL DESIGN

Models 1000-2500:

- 120-208-230VAC/60HZ/1PH - High Voltage
 (1500 to 2500 - Optional 208-230-460VAC/60HZ/3PH)

Models 3000:

- 208-230-240VAC/60HZ/1PH - High Voltage
 - 208-230-240-460VAC/60HZ/3PH - High Voltage

Models 3500-4000:

- 208-230-240-460VAC/60HZ/3PH - High Voltage
 - PCB (Printed Circuit Board) Fused Connections
24VAC/5VDC - Low Voltage PCB
 - EMS Communications
 (Dual RJ45 Jacks for Peer-To-Peer or ModBus)
 - Boiler Options (Sensors)
 - Pumps (Boiler, DHW, System) & Auxiliary Devices

OPTIONAL EQUIPMENT

- Hydronic Kit (Boiler Circulation Pump, Pump Flange Kit and Condensate Neutralizer)
- External High Limit Temperature Control, Manual Reset
- Condensate Neutralizer
- Supply Header Temperature Sensor:

<input type="checkbox"/>	Direct Immersion
<input type="checkbox"/>	Wired
- Outdoor Air Temperature Sensor:

<input type="checkbox"/>	Well Immersion (with Well)
<input type="checkbox"/>	Wireless
- EMS Signal Converter Kit (Converts Energy or Building Management System 0-10v signal to 4-20mA)
- Motorized Isolation Valves
- Alarm Buzzer with Silencing Switch
- Gas Valve Proving Switch
- Vent Adapter - CPVC
- Universal Communications Gateway (BACnet, Metasys, Modbus or Lonworks)
- Stackable Rack
- Conductor Sequencing Panel

The Conductor manages multiple condensing & non-condensing, small & large heat output, new and/or existing boilers (full modulation or on-off), and steam or hot water applications. It helps improve system efficiency by selecting and modulating the right boiler to match operating conditions. The Conductor offers a single point boiler plant Energy Management System (EMS) interface including Modbus TCP/IP, Modbus RTU RS485, BACnet/IP and BACnet MSTP standard. If Lonworks needed, add for the separate Lonworks gateway.

Extended Warranty

- 3-Year Parts
 5-Year Parts
 10-Year Parts
 5-Year Parts/Labor
 10-Year Parts/Labor

AMP CONDENSING BOILERS - SUBMITTAL DATA SHEET

CONCERT CONTROL FEATURES

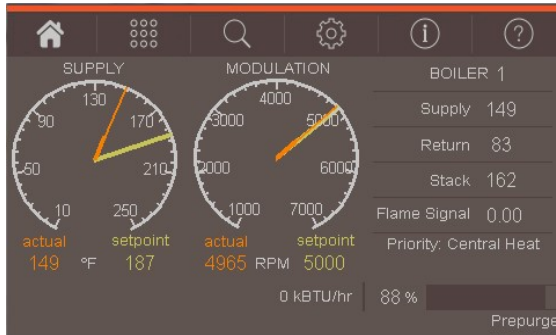

Dashboard - Color Touchscreen Display, 4"

- Intuitive Icon Navigation
- "Quick" Setup Menus
- *Real Time BTU/H Display

Two (2) Temperature Demand Inputs

- Outdoor Air Reset Curve for Each Input
- Time of Day Setback Capability
- (Envirocom Thermostat must be installed)

Three (3) Pump Control

- Boiler Pump With On/Off or Variable Speed Control
- Domestic Hot Water (DHW) Pump
- System Pump
- Alternative Control to Combustion
 - Air Damper or Standby Loss Damper
- Pump Overrun for Heat Dissipation
- Pump Exercise
- Pump Rotor Seizing Protection

Peer-to-Peer Boiler Communications

- Multiple Size Boiler Sequencing Up to 8 Units
- *Two (2) Boiler Start/Stop Trigger
- Lead Boiler Automatic Rotation

Energy Management System (EMS) Interface

- *Firing Rate and Water Temperature Based Algorithms for Multiple Boilers; loss of EMS signal defaults to local boiler settings
- 420mAdc Input/Output (010Vdc Optional Converter)
- ModBus Input/Output (BACnet or LonWorks Optional Gateway)
- Simultaneous Interface with PeertoPeer

USB Data Port Transfer

- Upload Settings Between Boilers
- Download Parameters for Troubleshooting
- Import Data into .CRV Formatted Files for Performance Analysis

* Unique to Concert



Energy Efficiency Enhancer

- AntiCycling Technology
- Multiplier boiler base load common rate
- Outdoor Air Temperature Reset Curve
- Warm Weather Shutdown
- Boost Temperature & Time
- Ramp Delay
- OverTemperature Safeguarding

Self-Guiding Diagnostics

- Identifies Fault
- Describes Possible Problems
- Provides Corrective Actions
- Time/Date Stamp on Alarms and Lockouts

Unmatched Archives

- Historical Trends Collects Up to 4 months Data
- Event History Up to 3000 Alarms, Lockouts and Cycle & Run Times
- Alarm Limit String Faults, Holds, Lockouts and Others
- Cycle & Run Time Boilers & Pumps
- Resettable (Lockouts/Alarms/Cycles & Run Time)

Domestic Hot Water Priority

- DHW Tank Piped With Priority in the Boiler Loop
- DHW Tank Piped as a Zone in the System With the Pumps Controlled by the Concert Control
- DHW Modulation Limiting
- Status Screens
- Sensor Monitoring and Control

Other Features

- Factory Default Settings
 - Three Level Password Security
 - Frost Protection
- Contractor Contacts (Up to 3)
- Low Water Flow Safety Control & Indication
- Proportion Integral Derivative (PID) Parameters for Central Heat, DWH, Sequencer and Fan
- Built-in Brown-Out Protection